

## Special suction HVG

Suction width:18mm

# HANWHA



Utility

### Product characteristics

- \* Small and flexible design
- \* High strength aluminum alloy
- \* Adopts HANWHA's unique efficient valve body technology to save 50% gas consumption
- \* Suitable for small pieces with smooth surfaces
- \* European original imported sealed sponge pad, longer life



### Product structure

- \* (1) Mounting holes
- \* (2) P: G1/8 screw, air inlet
- \* (3) inlet sealing sponge pad
- \* (4) The appliance contains a high-quality generator

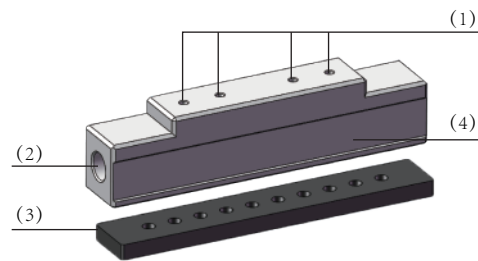

### Product advantages

- \* Very small size is best installed in limited space, short cycle cycle, good energy saving effect.



\* HVG case

# Special suction HVG

**HANWHA**



Utility

Suction width:18mm

## HVG Ordering NO

HVG	104	18
1	2	3

1-Series	2- Suction length	3- Suction width
HVG	104mm	18mm

## HVG Technical Data

Models	Use fluid	Suction N [-60KPA]	Intake pressure [Mpa]	Air consumption [L/Min]	Vacuum pressure reached [-Kpa]	Sponge aperture [MM]	Sponge pore number	Weight [KG]
HVG104X18	air	7.5	0.4-0.5	28	90	4	10	0.1

\*Vacuum degree is the reference value - please refer to the actual vacuum source performance value for the Kpa of the vacuum suction tool

## HVG Specification

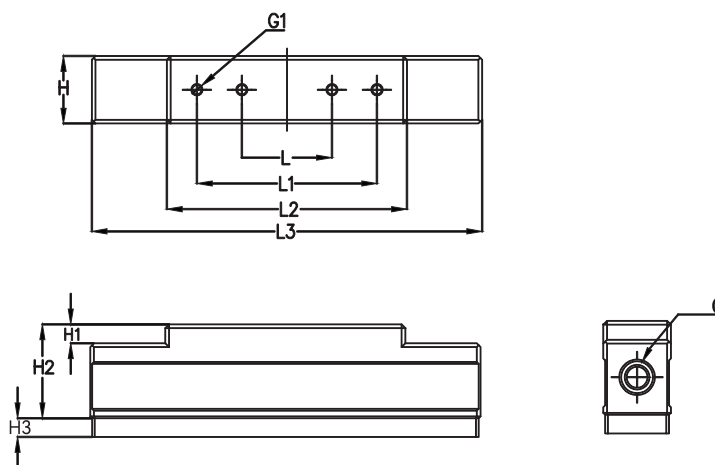

HVG104X18

model

Size[mm]	L	L1	L2	L3	H	H1	H2	H3	G	G1
HVG104X18	22	48	64	104	18	5	25	5	G1/8	4-M3